

Proposal

Biomethane plant using 1000 tpd Napier Grass
62-76 tpd bioCNG

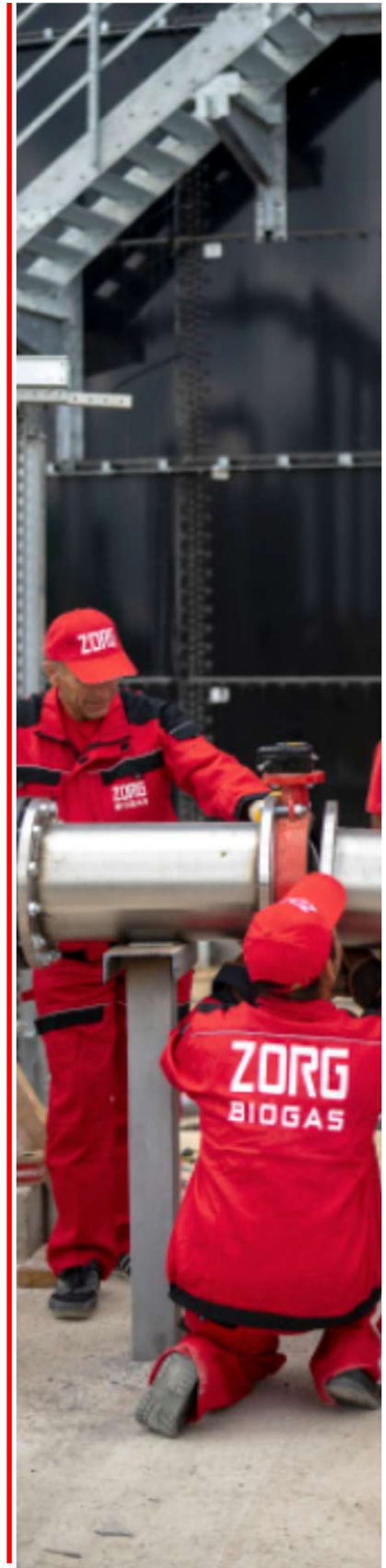

Date: 06/05/2016
Validity: 10 months



CONTENT

| | |
|---|----|
| Overview | 3 |
| Raw material potential | 4 |
| Biogas plant characteristics | 5 |
| Working principle | 6 |
| Technological process of biogas production | 7 |
| Main equipment | 8 |
| Solid feeder | 9 |
| Reactors | 10 |
| Reactor vertical agitator | 11 |
| Post-digester | 12 |
| Giant paddle agitator | 13 |
| Window with spotlight | 14 |
| Pump equipment | 15 |
| Separator | 16 |
| Filtrate tank and receiving tank | 17 |
| Submersible mixer | 18 |
| Gasholder | 19 |
| Biogas cooling system | 20 |
| Biogas compressor | 21 |
| Desulphurization system | 22 |
| Biogas burner | 23 |
| Biogas upgrading to biomethane (amine scrubber) | 24 |
| Water supplying and sewerage system | 26 |
| Heating system | 27 |
| Dry cooler (cooling substrate system) | 28 |
| Automation and electrical equipment | 29 |
| Sensors set | 30 |
| Laboratory | 31 |
| Specification list | 32 |
| | |
| Appendices: | 37 |
| Appendix 1. Material flow diagram | 38 |
| Appendix 2. Basic diagram | 39 |
| Appendix 3. Plan of biogas plant | 40 |
| Appendix 4. Electric power consumption | 41 |
| Appendix 5. Prices for equipment and Zorg' services | 42 |
| Appendix 6. Terms and payments | 43 |
| Appendix 7. List of exclusions | 44 |



OVERVIEW

We offer a solution for converting 1000 tonnes Napier grass/day into biomethane 62-76 tonnes/day depending on moisture content in the grass.

Amine scrubbers are used for upgrading. They produce the bioCNG of the highest purity (up to 99.9%) and consume half the energy of membranes or VPSA. Amine scrubbers are also less expensive than membranes or VPSA.

The digestion process will take place in the high-load reactors (HLR). The proposed HLR technology is superior to the conventional CSTR system. HLR reactors are three times smaller and 2 times cheaper.

The proposed concept differs from other solutions in its innovative feedstock logistics design. A central conveyor system is used to feed each digester, eliminating the need in frontal loaders. This significantly reduces manual operations and fuel consumption. The Napier grass is protected from rain, as all feeders are enclosed, ensuring a clean and organized facility area.

Zorg provides the detailed engineering, equipment supply, and supervision during construction, as well as training and start-up support. Construction and installation works are carried out by the Client under Zorg's supervision.

Raw material potential

Potential biomethane production with 27%DM

| Substrate | Quantity (tonnes/day) | Quantity (tonnes/year) | DM content: (%) | ODM content (%) | DM quantity (tonne s/ day) | ODM quantity (tonnes / day) | Biogas yield (m ³ / tonneODM) | Biogas (m ³ /day) | Methane content (%) | Biomethane (m ³ /day) | |
|--------------|-----------------------|------------------------|---|-----------------|----------------------------|-----------------------------|--|------------------------------|---------------------|----------------------------------|--------|
| Napier grass | 1000 | 365 000 | 27 | 96 | 270,0 | 259,2 | 690 | 178 848 | 52 | | |
| | | | Biogas for burning in boiler room to produce heat | | | | | | -15 017 | 52 | |
| | | | Biogas upgrading to biomethane | | | | | | 163 830 | 52 | 85 708 |

Potential biomethane production with 30%DM

| Substrate | Quantity (tonnes/day) | Quantity (tonnes/year) | DM content: (%) | ODM content (%) | DM quantity (tonne s/ day) | ODM quantity (tonnes / day) | Biogas yield (m ³ / tonneODM) | Biogas (m ³ /day) | Methane content (%) | Biomethane (m ³ /day) | |
|--------------|-----------------------|------------------------|---|-----------------|----------------------------|-----------------------------|--|------------------------------|---------------------|----------------------------------|--------|
| Napier grass | 1000 | 365 000 | 30 | 96 | 300,0 | 288,0 | 690 | 198 720 | 52 | | |
| | | | Biogas for burning in boiler room to produce heat | | | | | | -16 686 | 52 | |
| | | | Biogas upgrading to biomethane | | | | | | 182 033 | 52 | 95 231 |

Potential biomethane production with 33%DM

| Substrate | Quantity (tonnes/day) | Quantity (tonnes/year) | DM content: (%) | ODM content (%) | DM quantity (tonne s/ day) | ODM quantity (tonnes / day) | Biogas yield (m ³ / tonneODM) | Biogas (m ³ /day) | Methane content (%) | Biomethane (m ³ /day) | |
|--------------|-----------------------|------------------------|---|-----------------|----------------------------|-----------------------------|--|------------------------------|---------------------|----------------------------------|---------|
| Napier grass | 1000 | 365 000 | 33 | 96 | 330,0 | 316,8 | 690 | 218 592 | 52 | | |
| | | | Biogas for burning in boiler room to produce heat | | | | | | -18 355 | 52 | |
| | | | Biogas upgrading to biomethane | | | | | | 200 236 | 52 | 104 754 |

*-DM- Dry matter

**-ODM- organic dry matter

Biogas plant characteristics

| Characteristics | Values | Figures |
|--------------------------------------|----------------------|---------|
| Number of reactors | units | 9 |
| Volume: | | |
| Work | m ³ | 3720 |
| Overall | | 4005 |
| Temperature | °C | 52 |
| Overall dimensions of the reactor: | | |
| diameter | m | 27 |
| height | | 7 |
| Organic load | kgODM/m ³ | 7,74 |
| Hydraulic retention time (gross/net) | days | 36/34 |
| Number of post-digester | units | 1 |
| Volume: | | |
| Work | m ³ | 9360 |
| Overall | | 10173 |
| Overall dimensions of the reactor: | | |
| diameter | m | 36 |
| height | | 10 |
| Number of gasholders | units | 1 |
| Volume: | m ³ | 2905 |
| Dimensions of the gasholder: | | |
| diameter | m | 36 |
| height | | 7,2 |

Number of personnel

| | Shift 1 | Shift 2 | Shift 3 |
|------------------|---------|---------|---------|
| Plant manager | 1 | - | - |
| Chief engineer | 1 | - | - |
| Operator | 1 | 1 | 1 |
| Driver | 1 | 1 | 1 |
| Electrician | 1 | - | - |
| Mechanic | 1 | - | - |
| Guard (watchman) | 1 | - | - |
| Total | 11 | | |



Biogas plant working principle



The technology is based on the biochemical conversion of organic materials from high molecular weight compounds to low molecular weight compounds. The first stage of this process is hydrolysis. Hydrolysis produces organic acids and alcohols.

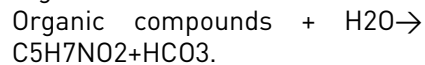

Further conversion of obtained dissolved compounds like organic acids and alcohols (C₅H₇NO₂, HCO₃) into gases - CH₄, CO₂. C₅H₇NO₂ + HCO₃ + H₂O → CH₄ + CO₂ + NH₄.

Biological process of consecutive (phasic) conversion of organic compounds take place in anaerobic environment i.e. in oxygen-free tank (biological reactor). At the first stage of fermentation, substrate hydrolysis take place under acidogenic bacteria influence. At the second stage, elementary organic compounds come through hydrolysis oxidation by means of hetero-acidogenic bacteria with production of acetate, carbon dioxide, and free hydrogen. The

other part of the organic compound including acetate forms C₁ compounds (elementary organic acids). Produced substances are the feedstock for methanogenic bacteria of the third type. This stage flows in two processes of A and B type the character which depends on caused by different bacteria type. These two types of bacteria convert the compound obtained during the first and second stages into methane CH₄, water H₂O and carbon dioxide CO₂. Methanogenic bacteria are more sensitive to the living environment compared to acidogenic bacteria. They require a complete anaerobic environment and a longer reproduction period. The speed and scale of anaerobic fermentation depends on bacteria metabolic activity. That is why the biogas plant chemical process includes hydrolysis stage, oxidation, and methanization stage. For that kind of substrate, these processes take place in the same reactor

Technological process of biogas production

Napier grass is transported to a biogas plant area and discharged into loaders with conveyor transportation line. The loaders input all substrates by portion to reactors using augers. In the reactors the substrate is brought up to a temperature of +52°C. Constant temperature is sustained for the entire digesting period. To prevent a rise in temperature (for example, in summer), the biogas station is equipped with a cooler (dry cooling). The reactors operating regime is thermophilic. The heated substrate in the digesters is blended periodically. Mixing is performed by vertical agitators. The average time of processing in the reactors is 34 days. After the reactors, the substrate is fed by pump to the post-digester which is equipped with a gasholder roof. After post-digester the substrate is supplied to a separation area where it is separated into solid and liquid bio-fertilizer. Solid bio-fertilizer is discharged from the separation area and transported for storage; liquid filtrate is directed to a storage. Biogas goes up under overlap of the reactors and delivered into the gasholder of the post-digester through pipelines. The gas holder's weather protective film protects the gasholder from precipitation and damage by foreign objects. The weather protective film is fixed firmly by a special system. To protect the gasholder from overpressure, digesters are equipped with safety

valves, which start working at a pressure of 5 mbars and bleed biogas to the atmosphere.

Then accumulated in gasholders biogas goes through a gas pipeline to a biogas cooler with a condensate discharge unit and then to a compressor, where the pressure is raised up to 80-150 mbar to meet engine requirements. After the compressor, biogas is fed to activated coal filters to remove hydrogen sulfide (H₂S). After filters, biogas goes to an amine scrubber optimized for biogas upgrading to biomethane, where raw biogas treats through the removal of CO₂ and other soluble gases to produce primarily methane gas (~99%) which is clean and dry and has the same characteristics as natural gas.

All technological processes are controlled and operated by an automatic system. Biogas plant work is monitored at the central control room monitor. The control room is equipped with a central control unit, which allows the switching of any biogas plant module into automatic or manual mode with local or remote control.

MAIN EQUIPMENT

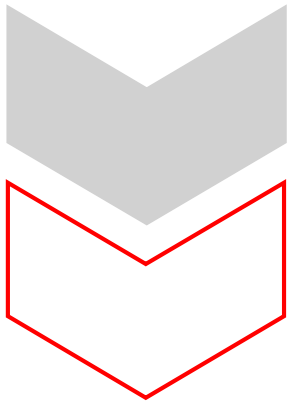



Solid feeder (SF-01 ... SF-09)

Solid feeder machines have been proven in various situations. Solid feeder has the solid design, which guarantees a maximum functionality and less maintenance, combined to a low energy consumption. Because of the vertically oriented walls, there is no change for the material to get stuck or build bridges. The conveyor chains and the milling-unit allow continuous dosing by various types of materials. Furthermore, the material is loosened by this dosing process. The user is able to control the material flow up to 20m³/h or more, regarding to the own consumption of electrical power by the machine. In addition, the corrosion protection, wear resistance and high quality allow customers to use our product for a long period of time.

Specifications

| | |
|------------------|-------------------------|
| Height: | 2,6 m |
| Length: | 7,0 m |
| Width: | 2,8 m |
| Volume: | 15 m³ |
| Quantity: | 9 pcs. |



Reactor (R-01... R-09)

Reactor is a tank of cylindrical form (for better mixing during the fermentation). It is built of cast-in-situ reinforced concrete based on sulphate-resistant cement with thickness of walls and bottom - 0,25m. Overlap of reactor is reinforce concrete plate. On the tank's wall and in the bottom there is to be installed pipelines for heating, intended for assurance and maintenance of the optimal fermentation process temperature at thermophilic conditions. For heat conservation and reduction of heat energy consumption, the reactor walls, overlap and bottom are insulated outside with 100 mm slabs of extruded polystyrene foam. Over the heater, the substructure walls and bottom are insulated with roll damp proofing. Superstructure and substructure heat insulation is protected by shaped sheet from the outside mechanical damages and rodents. The reactor`s bottom has a slope 1%.

Specifications

| | |
|-------------------------|---------------------------|
| Height: | 7,0 m |
| Diameter: | 27,0 m |
| Total volume: | 4005 m³ |
| Substrate volume | 3720 m³ |
| Quantity: | 9 pcs. |

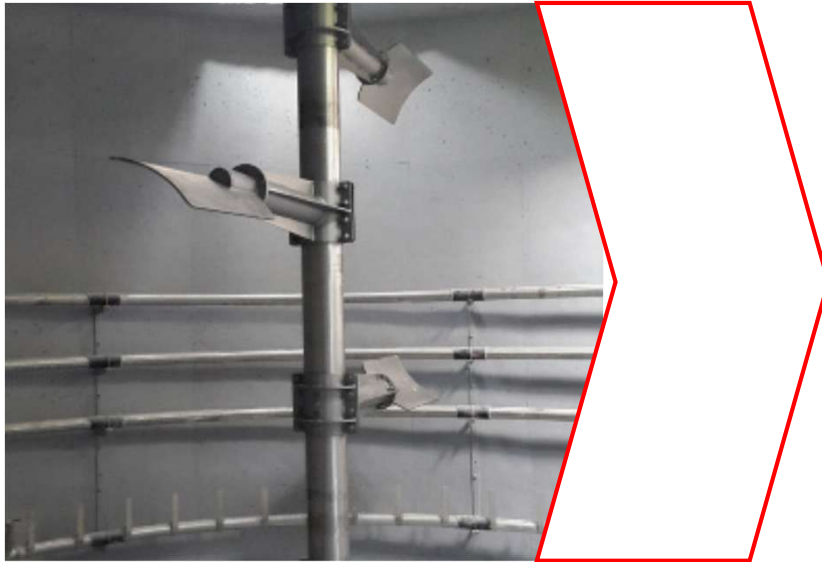

Reactor vertical agitator (AG-01 ... AG-54)

Vertical agitators are designed and engineered to guarantee high energy efficiency. We use gear units and motors from respected European manufacturers. This guarantees the long life of our mixers. All motors and gear units are available with ATEX certifications.

Agitators are designed for mixing substrates with a high solids content of 13-18%. The blades of the mixers are set at an optimum angle, and the external motor of the mixer is mounted on a special support.

Specifications

| | |
|-----------------------|--------|
| Engine power: | 15 kW |
| Quantity per reactor: | 6 pcs |
| Total quantity: | 54 pcs |



Post-digester (PD-01)

It is a tank of cylindrical form. It is built of cast-in-situ reinforced concrete based on sulphate-resistant cement with thickness of walls and bottom - 0,25m. In the center of the reactor there is a column with chapter. From the walls of the reactor to the central column, are fixed support belts for the biogas membrane of the gas holder. Gasholder is a half-spheric tank of membrane PELD. Biogas is collected to it during the process of anaerobic fermentation of raw materials. For heat conservation and reduction of heat energy consumption, the pos-tdigester walls and bottom are insulated outside with 100 mm slabs of extruded polystyrene foam. Over the heater, the substructure walls and bottom are insulated with roll damp proofing. Superstructure and substructure heat insulation is protected by shaped sheet from the outside mechanical damages and rodents.

Specifications

| | |
|-------------------------|-----------------------------|
| Height: | 10,0 m |
| Diameter: | 36,0 m |
| Total volume: | 10 173 m³ |
| Substrate volume | 9360 m³ |
| Quantity: | 1 pcs. |

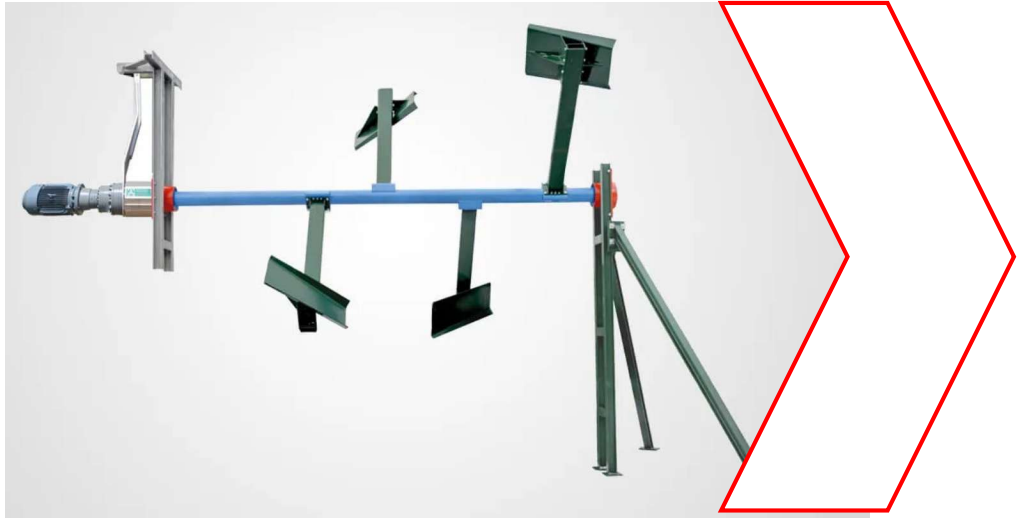

Paddle giant agitator (AG-55 ... AG-59)

Inclined paddle agitator with high agitator power is designed and engineered to high effectiveness also with high-viscosity media. Gentle treatment of the bacteria population in order to attain an optimum gas yield. Container bearing consisting of special, extremely wear resistant and methane-free bearing plastics. All relevant components can be replaced without having to drain the container or replacing the agitator shaft. The functional principle is ideal for breaking floating layers. The functional principle supports the agitation of setting layers. Degassing of the substrate is made easier. This agitator type is suitable for slightly fluctuating filling levels. We use gear units and motors from respected European manufacturers. This guarantees the long life of our mixers. All motors and gear units are available with ATEX certifications.

Specifications

| | |
|------------------------------|--------------|
| Engine power: | 11 kW |
| Quantity per reactor: | 5 pcs |
| Total quantity: | 5 pcs |



Window with spotlight (SG-01... SG-09)

Inspection windows are designed for visual control of processes inside the fermenter. Spotlights were made in explosion-proof with automatic disconnection. Inspection windows are equipped with a cleaning washing system.

Specifications

Inspection windows: Ø300

Spotligh: 230V, 50W, IP65
VISULUX UL50 -G -H



Pump equipment

Pumps are used to transport substrate to the equipment and facilities in the biogas plant and away. Biogas plant design allows to access easily to all pumps. Pumps are driven by helical geared motor. Stator has hopper inlet for optimum filling of the pumping chamber, wear-protected, robust universal joint with feeding screw, robust bearing pedestal with close-coupled drive and self-centering of the drive shaft. Pumps have modular design for high flexibility, low life-cycle-costs.

Specifications

Liquid substrate pump (PU-14, PU-15)

| | |
|---------------|-------------------------|
| Engine power: | 18,5 kW |
| Flow rate: | 60 m ³ /hour |
| Pressure: | 2 bar |
| Quantity: | 2 pcs |

Substrate pump (PU-01... PU-09)

| | |
|---------------|-------------------------|
| Engine power: | 11 kW |
| Flow rate: | 40 m ³ /hour |
| Pressure: | 2 bar |
| Quantity: | 9 pcs |

Digested substrate pump (PU-10, PU-12)

| | |
|---------------|-------------------------|
| Engine power: | 18,5 kW |
| Flow rate: | 60 m ³ /hour |
| Pressure: | 2 bar |
| Quantity: | 2 pcs |

Filtrate pump (PU-12, PU-13)

| | |
|---------------|-------------------------|
| Engine power: | 18,5 kW |
| Flow rate: | 60 m ³ /hour |
| Pressure: | 4 bar |
| Quantity: | 2 pcs |



Separator (SR-01... SR-09)

The Press Screw Separator covers a broad spectrum of applications, from agriculture to biogas and bioethanol plants. The innovative technology separates substrates in its solid and liquid elements. The secret of the versatility of the press screw separator is that it can adjust to different dry matter contents and Thick liquids (20% dry matter content). Slotted screens have different assortment and width of table cells and give possibility work with small solids and fiber contents. In the slotted screen, the solids are screened out from the liquid. The solids build up a layer which also acts as a filter to separate finer particles from the liquid. The auger flights convey this layer to the solids outlet. The screen surface is cleaned and a new filter layer is formed. The design of the screens is not conducive to plugging. The pressure in the first part of the screen is low but increases with the solid consistency to the solid output. The consistence of the gained solid can be varied with the help of a output regulator by the amount and position of counter weights. This way the required consistency of the final product for either further storage, use as fertilizer or the basis for compost can be reached. The liquid phase can easily be drained through a pipe or hose system.

Specifications

| | |
|----------------------|---------------------|
| Engine power: | 5,5 kW |
| Flow rate: | 8-30 m3/hour |

| | |
|------------------|--------------|
| Quantity: | 9 pcs |
|------------------|--------------|

Equipment
Frame
Screw
Sieve for the filtration
Counterweights
The design of the protective room



Filtrate tank and Receiving tank (FT-01, RT-01)

Reinforced concrete reservoir for reception of liquid kinds of raw materials. The reservoirs are equipped with level sensors and submersible agitators for mixing substrate.

Receiving tank is for reception liquid substrate like pig manure, cattle manure etc, for plant start-up. Reservoir serves to collect and mix and preheat substrate before supplying to the reactors.

Filtrate tank serves like a buffer tank to collect filtrate after separation area and discharge it to the lagoon,

Specifications

Receiving tank

| | |
|----------------------|--------------------------|
| Diameter: | 8,0 m |
| Height: | 3,0 m |
| Total volume: | 150 m³ |

| | |
|------------------|--------------|
| Quantity: | 1 pcs |
|------------------|--------------|

Filtrate tank

| | |
|----------------------|--------------------------|
| Diameter: | 10,0 m |
| Height: | 3,0 m |
| Total volume: | 235 m³ |

| | |
|------------------|--------------|
| Quantity: | 1 pcs |
|------------------|--------------|



Submersible mixer (AG-60, AG-61)

The submersible motor agitator serves for mixing renewable raw materials (RRM), liquid substrate as manure and similar substrates. The electro-motor driven submersible agitator is designed for submersion operations in potentially explosive environments of Ex zone 2 and complies with Directive 94/9 EC. The submersible agitator can be attached to most sliding masts by means of the motor support. A mounting option for a hauling cable is provided on the motor support for height adjustment purposes.

Due to the 4-roller guidance of the motor support, the agitator can be lifted and lowered without friction and the square mast, even if the pull of the hauling cable is slightly angular. The motor support is designed for a 100 x 100 mm square sliding mast as standard, but can also be used for an 80 x 80 mm sliding mast by changing the rollers. The strain relief of the connecting cable can be positioned in the extension of the motor or towards the top on the motor support, depending on the requirements. This enables universal utilization with the most various installation kits.

The geared motor is made of spheroidal graphite iron (GGG40) and painted, the propeller is galvanized and the motor support is made of stainless steel. The submersible motor agitator is designed as a water pressure-tight monoblock unit for driving the three-vane propeller. The submersible agitator is of modular design, submersible electro-motor with flange-mounted planetary gear and bearing flange for holding the propeller. The conical shaft in the bearing flange is mounted in the oil bath by two angular roller bearings and sealed off from the agitating substrate with a mechanical seal.

Specifications

Agitator for the filtrate tank (AG-60)

| | |
|-----------------------|---------------|
| Nominal power: | 5,5 kW |
| Quantity: | 1 pcs |

Agitator for the receiving tank (AG-61)

| | |
|-----------------------|---------------|
| Nominal power: | 5,5 kW |
| Quantity: | 1 pcs |



Gasholder

The gasholder provides for biogas storage and for equalizing pressure and biogas composition. The gasholder system has a two-layer construction. The external material consists of a weather-proof film of PVC-coated polyester fabrics with UV protection. Both sides are finished with an external N/5cm, internal membrane PELD (gasholder) membrane.

The gasholder has a methane permeation maximum of $260 \text{ cm}^3/\text{m}^2 \cdot 1 \text{ bar}$ biogas resistance. The gasholder film temperature range allows operation from -30°C to $+60^\circ\text{C}$.

The internal film is stretched under normal biogas pressure. Air is blown into the space between the external and internal membranes to pressurize the internal membrane and form the shape of the external membrane.

The biogas pressure in the gasholder is 2-5 mbar. The membranes are designed and cut out on NC machines. Welding is executed by high frequency currents. These steps yield substantial improvements for quality and service life compared to handmade membranes welded by standard welding equipment.

To prevent damage to the gasholder as a result of overpressure conditions, a safety valve is installed. To survey the internal membrane, an inspection window is installed on the external membrane.

Specifications

| | |
|---------------------------|---------------------------|
| Height: | 7,2 m |
| Diameter: | 36,0 m |
| The total volume : | 2905 m³ |
| Quantity: | 1 pcs |

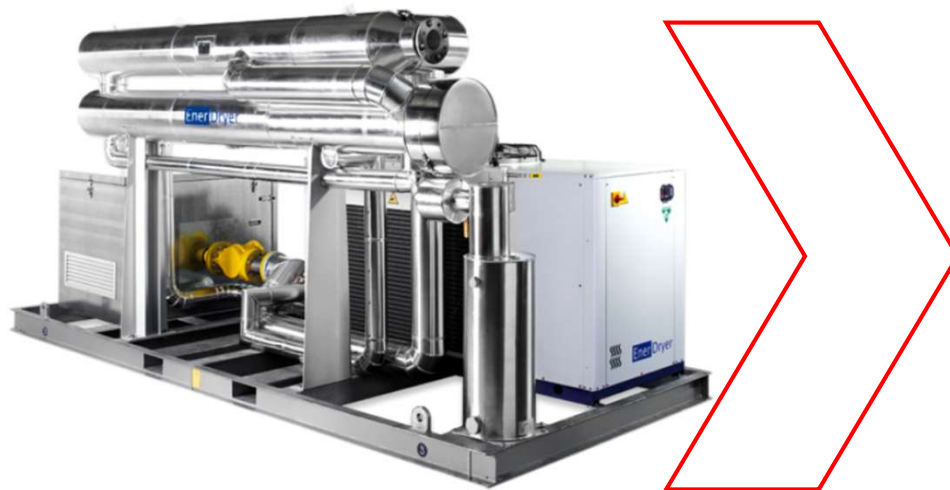

Biogas dryer and cooling (CHL-01... CHL-04)

Biogas dryer and cooling are provided with special equipment as GAS COOLER and AIR-COOLED LIQUID CHILLER. Biogas plants thanks to an extensive range of dedicated Biogas solutions, low pressure heat exchangers, a comprehensive range of water chillers and RWD Dry Coolers. Designed as one-way shell-and-tube heat exchanger. Process gas inside of the tubes; cooling water in the shell. All parts in contact with the process gas made of stainless steel 316Ti or 316L; heat exchanger shell made of stainless steel/ Designed with gas outlet chamber outlet connection radial; inspection opening axial Official acceptance according to PED 2014/68/EU in accordance with ADMerkblätter and factory pressure test.

Specifications

| | |
|--------------------------------|--------------------------------|
| Gas volume flow: | 3750 m³/hour |
| Gas inlet temperature: | +55°C |
| Gas outlet temperature: | +10°C |
| Electric power: | 65 кВт |
| Quantity: | 4 pcs |



Biogas compressor (BC-01, BC-02)

Biogas blower is a device used to move gas and increase pressure thanks to a rotating impeller within a toroidal channel, so there is a progressive increase of energy.

Blower is used to transporting biogas from gasholder storage to consumer (biogas upgrading plant in our case).

Specifications

| | |
|---------------|---------------------------|
| Flow rate: | 7500 m ³ /hour |
| Pressure: | 150 mbar |
| Engine power: | 64 kW |

| | |
|-----------|-------|
| Quantity: | 2 pcs |
|-----------|-------|



Desulphurization system

The desulphurization system is a 3-step system. Stage 1 is adding Ferrum Hydroxide. Stage 2 - biological. Adding a certain portion of air to the fermenter. Air by special bacteria, converting H_2S into S. After 1 and 2 steps the sulphur concentration is 80 ppm. Stage 3 - activated charcoal filtration, as activated charcoal has the capability to absorb sulfur. After passing through activated charcoal filters, the sulfur concentration is reduced to 0 ppm.

Specifications

| | |
|-------------------------|----------------|
| Charcoal filter | (CF-01, CF-02) |
| The volume of charcoal: | 1000 kg |
| Quantity: | 2 pcs |

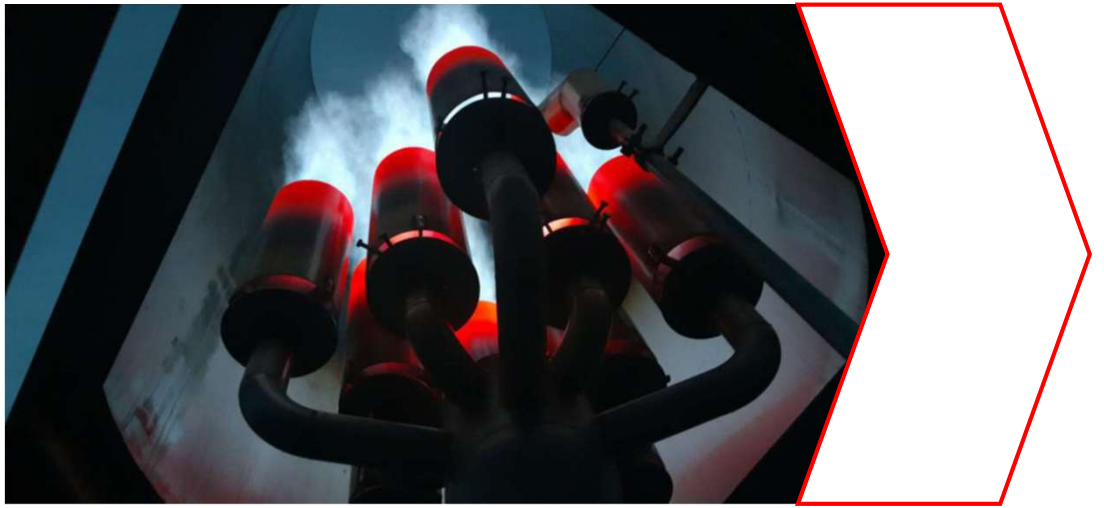

Flare

Flare is designed for the temporary or periodical complete combustion of the biogas produced by biogas plants without the possibility of its use as an energy source. The burn system consists of a burner and additional equipment. The burner is designed on the principle of injection and consists of a combustion nozzle with an injector with an air supply control system, flame protection tube, fitting and burner control system. The biogas combustion system is made of stainless steel.

The supporting structure holds the burner and vertically mounted socket. The burn control system is installed in a case, which is mounted on the supporting structure of the combustion system and contains all the elements for monitoring and controlling ignition and flame.

Specifications

| | |
|-------------------|-------------------------------------|
| Flow rate: | 3750 m³/hour |
| Pressure: | min 10 mbar- max 60 mbar |

| | |
|------------------|--------------|
| Quantity: | 2 pcs |
|------------------|--------------|



Biogas upgrading plant to biomethane Enrichment- Amine scrubber

The biogas upgrading plant is used to purify biogas, landfill gas or sewage gas. Amine scrubber technology, also known as amine gas treatment, is a widely used process for purifying biogas and converting it into biomethane. The amine scrubber technology utilizes a liquid solvent, usually an amine compound, to selectively remove impurities, particularly CO₂, from the biogas stream. The process involves several stages, including absorption, desorption, and regeneration. Here's an overview of the amine scrubbing process for biogas purification:

1. Absorption: The biogas is introduced into an absorption column where it comes into contact with the amine solvent. CO₂, being more soluble in the solvent than methane, is selectively absorbed from the gas stream. The purified methane exits the column and is collected as biomethane.
2. Desorption: Once the amine solvent becomes saturated with CO₂, it needs to be regenerated. This is achieved by heating the solvent in a separate desorption column, which releases the absorbed CO₂, resulting in a concentrated CO₂ stream. The regenerated solvent is then cooled and recirculated for reuse in the absorption column.
3. CO₂ Capture: The concentrated CO₂ stream produced during desorption can be further processed for capture or utilization. Depending on the specific requirements and goals, the captured CO₂ can be compressed and stored for various applications, include unenhanced oil recovery, carbon utilization, or even carbon sequestration.

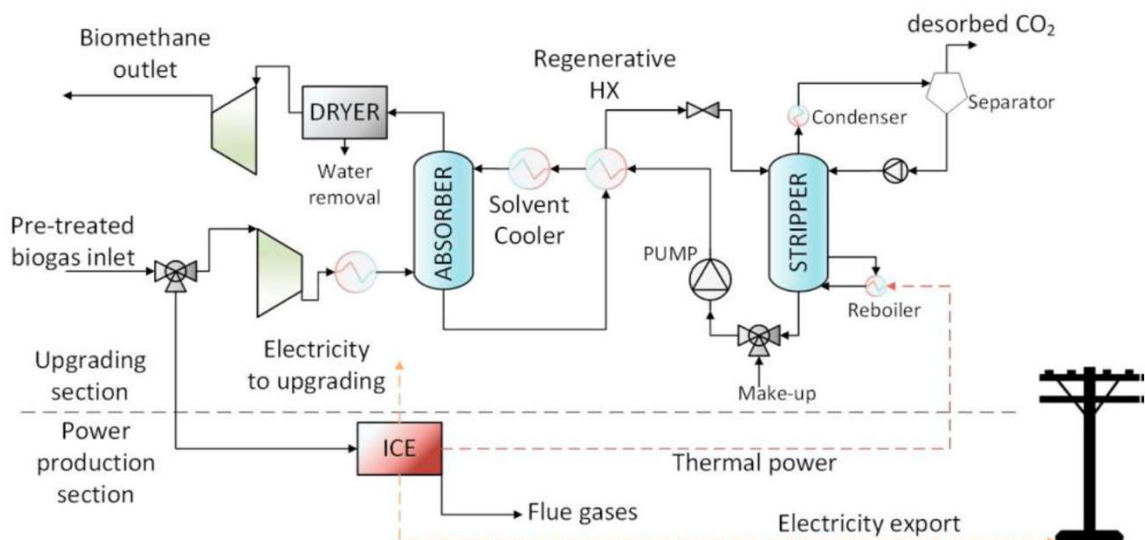

Biogas upgrading plant nominal conditions

| | Biogas | Biomethane | CO2 reach tail gas |
|---------------------------|--------|-----------------------|--------------------|
| Flow (Nm ³ /h) | 3450 | 1785 | 1532 |
| CH ₄ (Vol %) | 52 | 98 | 1,67 |
| CO ₂ (Vol %) | 55,2 | 2,6 | 96 |
| H ₂ O (Vol %) | 0,8 | Dew-point < - 65°C | 1,82 |
| N ₂ (Vol %) | 0,8 | 1,26 | 0,26 |
| O ₂ (Vol %) | 0,2 | 0,11 | 0,3 |
| H ₂ S (ppm) | <3 | - | - |
| Temperature (°C) | 20 | 25 | 40 |
| Pressure (bar) | 0,09 | 3,1 | 0,05 |

* Sulfur removal is two-stage:

-by iron hydroxide - the first stage of purification (in the digesters);

-by coal column - the second stage.

Amine scrubber technology offers several advantages for biogas upgrading to biomethane:

High Purity: The process can achieve high purity levels of methane, typically above 95%, making it suitable for biomethane injection into natural gas grids or direct use as a transportation fuel.

Selectivity: Amine solvents have a high affinity for CO₂, allowing for selective removal of this greenhouse gas from the biogas stream while preserving methane.

Scalability: Amine scrubbing technology is well-established and can be scaled up to handle large volumes of biogas, making it suitable for industrial-scale biogas upgrading facilities.

Flexibility: The process can be adapted to different biogas compositions and can handle variations in gas flow rates and impurity levels.

Specifications

Flow rate: 3450 m³/hour

Quantity: 2 pcs

Water supplying and sewerage system



Water supplying system provides biogas plant feed water, water for network circuits, the domestic water and fire safety systems. As used centrifugal single stage pumps as main pumping elements. These pumps are designed for pumping wastewater, household / domestic water and sewage. Pressure Boosting Systems are designed for pure water pressure boosting in industrial plants. The booster comprises 2 to 3 (connected in parallel pumps) installed on a common base frame, and provided with all the necessary fittings.

Specifications

Drain pump
Pressure 4m
Flow 2-3 m³ / h
Engine 0,24 kW

Equipment
Pump case control
Stove-base
gauges
Check valves
Float switches
Brackets
Valves



Heating system

Heating equipment is used for biogas plant heating and for sustaining constant temperature in the fermenter. Heating equipment includes circulation pumps, heat exchanger, heating manifold and pipes. The heat from the boiler is transferred to the biogas plant by using heat exchanger, and then is pumped through of biogas plant by circulation pumps. A heat carrier prepares water with an additive of ethylene glycol. Inlet temperature in the fermenter is 60C, the outlet is 40C.

Specifications

Circulating pump feeding heat carrier

| | |
|---------------|-------------------------|
| Engine power: | 3,5 kW |
| Flow: | 28 m ³ /hour |
| Pressure: | 6 bar |

Circulating pump feeding heat carrier

| | |
|---------------|------------------------|
| Engine power: | 2,0 kW |
| Flow: | 12m ³ /hour |
| Pressure: | 9 bar |

The pumping station feeding propylene glycol

| | |
|---------------|------------------------|
| Engine power: | 0,7 kW |
| Flow: | 1 m ³ /hour |
| Pressure: | 4 bar |



Dry cooler (cooling substrate system)

Device is designed to cool the substrate to working temperature according to technological regime. When use high temperature substrate, there is a chance of uncontrolled heating. The cooler is connected to the heating pipes, heat exchangers and it will be activated if it is need.

Specifications

| | |
|-----------------|--------|
| Heat power: | 100 kW |
| Electric power: | 4 kW |
| Quantity: | 9 pcs |

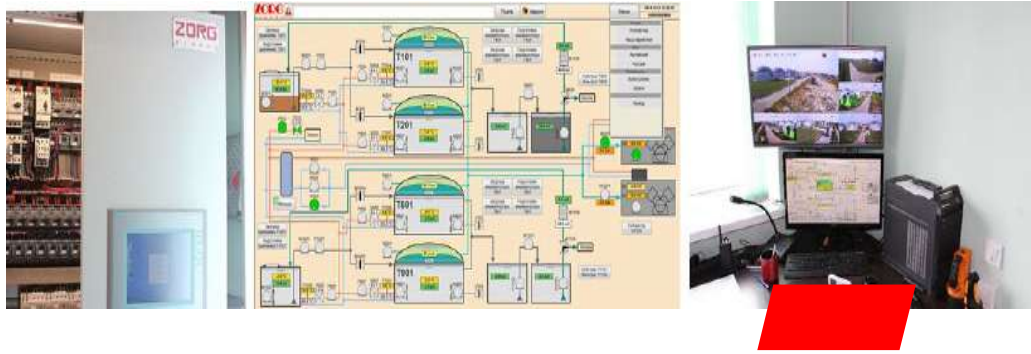

Automation and electrical equipment

Process control equipment is used for supervision and regulation operation of the plant and for the limitation of damage. In case of emergency (for example, breakdown of the electrical power supply) the biogas plant is automatically transferred to safe operating conditions by the process instrumentation. Critical electrically driven devices are supplied with emergency power. An automatic system allows the supervision of the plant in real time and to recognize and correct aberrations immediately; to run the plant at its optimum saving resources and costs; and to record for the electronic database operation parameters. The automatic system consists of a control cabinet and sensors for parameter control of technological processes and execution devices.

The control cabinet is designed based on the industrial controller Siemens CPU315-DP2, using periphery distributing system Simatic ET200S, and operator panel OP277 Touch with touch-sensitive controls. Communications is executed by PROFIBUS and MPI with physical interface RS-485. The control program is designed based on the Simatic Step7. The control cabinet is a modular design. The upper part has a power box with central and front-end processor. The periphery distributing system, Simatic ET200S, is installed with input - output units. The lower part with interface relay and clips is installed for connecting execution devices. The entire plant is controlled by a single operator.

Specifications

Incoming control case with automatic set ASE-1, 2, 3

Base Siemens CPU315-DP2 controller

Peripherals Simatic ET200S

Control panel OP277 touchscreen

Communication PROFIBUS and MPI

Interface RS-485

Control system Simatic Step7



Sensors set

Sensors are used to measure physical quantities (temperature, pressure, level of moisture) data collection.
installation kits

Specifications

Conductometric sensor

Pressure Sensor / level

Ultrasonic sensor

Gas Pressure Sensor

Temperature converters with protective sleeves

The moisture sensor and the gas temperature



Laboratory

Monitoring and control of parameters of raw materials and fermentation processes is important for the efficient operation of a biogas plant. The laboratory allows you to assess the content of dry matter in the input raw materials, fermented mass, determine the ratio of volatile organic acids to total inorganic carbon (FOS/TAC parameter), determine the degree of substrate fermentation in fermenters, the level of biogas output, and evaluate the efficiency of separator.

-

Equipment

Analytical scales

Moisture analyzer

Automatic titrator

Laboratory pH meter

Centrifuge

A set of flasks

Equipment specification list



| Nº | Equipment | Characteristic | Quantity |
|----------|---|--------------------------------|-----------|
| 1 | Loader | V=15m3 | 9 |
| 1.1 | Container bunker | | 9 |
| 1.2 | Feeding screws | set. | 9 |
| 2 | Submersible mixer | N=5.5kW | 2 |
| 2.1 | Airtight motor gearbox | | 2 |
| 2.2 | Hydraulic screw (wear-resistant steel) | | 2 |
| 2.3 | Mixer control mechanism | | 2 |
| 2.4 | Electric motor mount | | 2 |
| 2.5 | Set of fasteners | | 2 |
| 3 | Reactor vertical agitator | N=15 kW | 54 |
| 3.1 | Airtight motor gearbox | | 54 |
| 3.2 | Hydraulic screw (wear-resistant steel) | | 54 |
| 3.3 | Shaft (adapted to the height of the fermenter) | | 54 |
| 3.4 | Blade | | 54 |
| 3.5 | Frequency converter | | 54 |
| 3.6 | Mounting bracket to bottom of the mixer | | 54 |
| 4 | Giant paddle agitator | | 5 |
| 5 | Safety valve of digesters | | 10 |
| 6 | Window with a searchlight | set | 10 |
| 6.1 | Inspection window RD300 (mounts and sealant included) | Ø300 | 20 |
| 6.2 | Spotlight (mount system bundled) VISULUX UL50 -G -H | 230V, 50W, IP65 | 10 |
| 7 | Liquid substrate pump | 60m3/hour N=18,5 kW | 2 |
| 8 | Substrate pump | 40m3/hour N=11 kW | 9 |
| 9 | Substrate digested pump | 60m3/hour N=18,5 kW | 2 |

| Nº | Equipment | Characteristic | Quantity |
|-----------|--|---------------------------------|----------|
| 10 | Separator | N=5.5kW | 5 |
| 10.1 | Body | | 5 |
| 10.2 | Substrate Supply Pipe 4 '' | | 5 |
| 10.3 | Engine - Gearbox | N=5,5 kW | 5 |
| 10.4 | Frame | | 5 |
| 10.5 | Screw | | 5 |
| 10.6 | Sieve for filtration | | 5 |
| 11 | Filtrate pump | 60 m3/hour N=18,5 kW | 2 |
| 12 | PVC gas holder 1/5D | 2905m3 | 1 |
| 12.1 | Weather protection film | Ø36m | 1 |
| 12.2 | Gasholder film PE/HD methane permeation max.260 cm3/m2*d*1 bar, 650 N/5cm biogas resistant | | 1 |
| 12.3 | Air blower | 16A, 0,5kW | |
| 12.4 | Excess and minimum pressure valve | | 1 |
| 12.5 | Dome level sensor | | 1 |
| 12.6 | Mounting system | | 1 |
| 12.7 | Accessories | | 1 |
| 12.8 | Safety valve | | 1 |
| 13 | Biogas Cooling System | 1900m3/h | 4 |
| 13.1 | Chiller | | 4 |
| 13.2 | Heat exchanger | | 4 |
| 13.3 | Polypropylene glycol tank | | 4 |
| 14 | Desulphurization system | | 1 |
| 14.1 | Numbers of charcoal columns | 1000 kg | 2 |

| Nº | Equipment | Characteristic | Quantity |
|------|---|--|----------|
| 15 | Biogas compressor | Q=7500m3/h, H=150mBar, N=64kW | 2 |
| 16 | Electromagnetic flow meter | | 1 |
| 17 | Flare | 3750 m3/h | 2 |
| 18 | Gas equipment included | set | 1 |
| 18.1 | Drainage pump with float | DN=50, Q=1m3/h, H=13 m | 2 |
| 19 | The heat supply system | set | 1 |
| 19.1 | Diaphragm expansion tank | V=1000 l,P=6Bar T=120°C | 1 |
| 19.2 | Circulating pump for supplying heat carrier | Q=30 m3/h,H=1bar | 6 |
| 19.3 | Propylene glycol feed pump station heating systems | Q=1,0 m3/h, H=4 bar | 2 |
| 19.4 | Circulation pump for supplying heat carrier to the digester | Q=18 m3/h, H=1.1 bar | 9 |
| 20 | Water supply and sewerage system, complete, disassembled | set | 1 |
| 21 | Biogas upgrading to biomethane | 3450 m3/hour | 2 |
| 22 | Automation with electrical equipment | set | 1 |
| 22.1 | Incoming distribution cabinet with a set of automation DB-1 | | 1 |
| 22.2 | Incoming distribution cabinet with a set of automation DB-2 | | 1 |
| 23 | Sensors, set | | 1 |
| 23.1 | Gas pressure sensor 0,025Bar | | 9 |
| 23.2 | Gas pressure sensor 0,4Bar | | 2 |
| 23.3 | Pressure sensor(substrate level) 1,0Bar | | 13 |
| 23.4 | Pressure sensor (substrate pressure) 2,5bar | | 13 |

| Nº | Equipment | Characteristic | Quantity |
|-----------|--|----------------------------|----------|
| 23.5 | Resistive thermometer (gas temperature) | | 9 |
| 23.6 | Resistive thermometer with thermo well (fermenter substrate temperature) | | 9 |
| 23.7 | Resistive thermometer with thermo-well (digester tank substrate temperature) | | 9 |
| 23.8 | Resistive thermometer (heat conductor temperature) | | 13 |
| 23.9 | Conductometric sensor of maximum level | | 13 |
| 23.10 | Conductometric sensor of water level | | 13 |
| 23.11 | Dome position sensor | | 1 |
| 23.12 | Coolant pressure sensor | SEN 3276 B065 G1/2 6Bar | 9 |
| 23.13 | Humidity and gas temperature sensor | ESFTF-I | 2 |
| 24 | Dry cooler 100kW heat pow. | | 9 |
| 25 | Laboratory | set | 1 |

APPENDICES



Material flow diagram

Napier grass with 27%DM

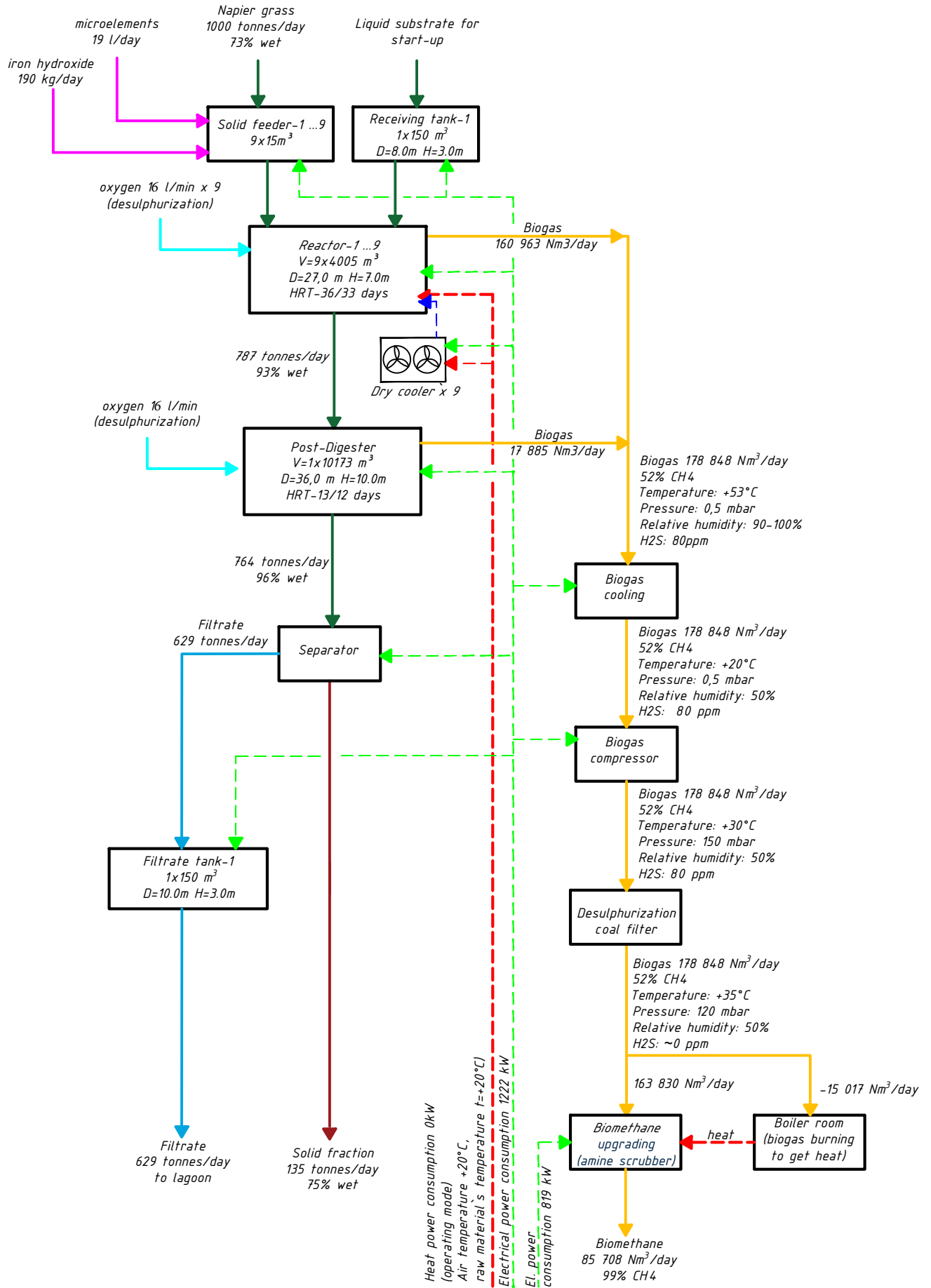

Material flow diagram

Napier grass with 33%DM

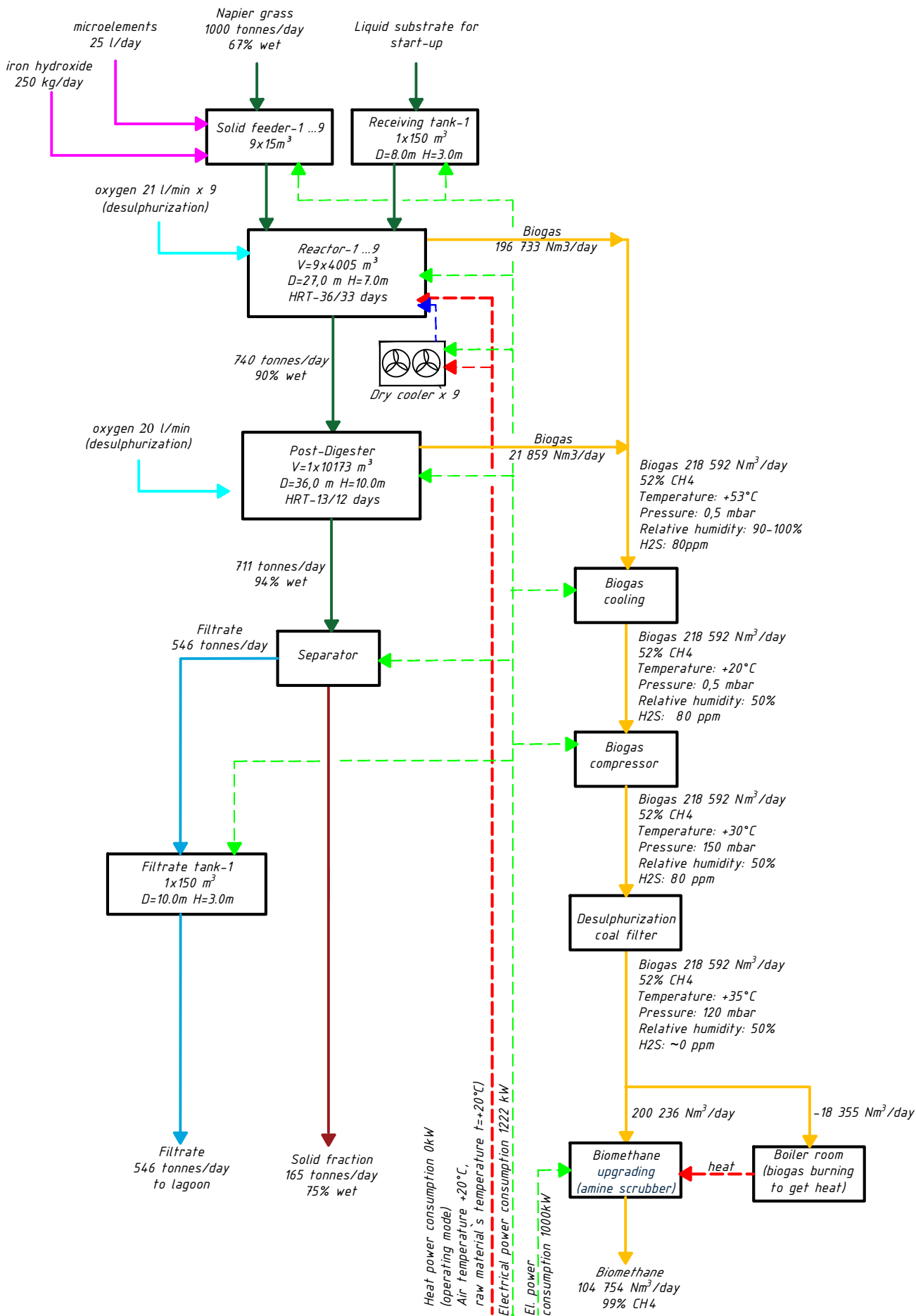

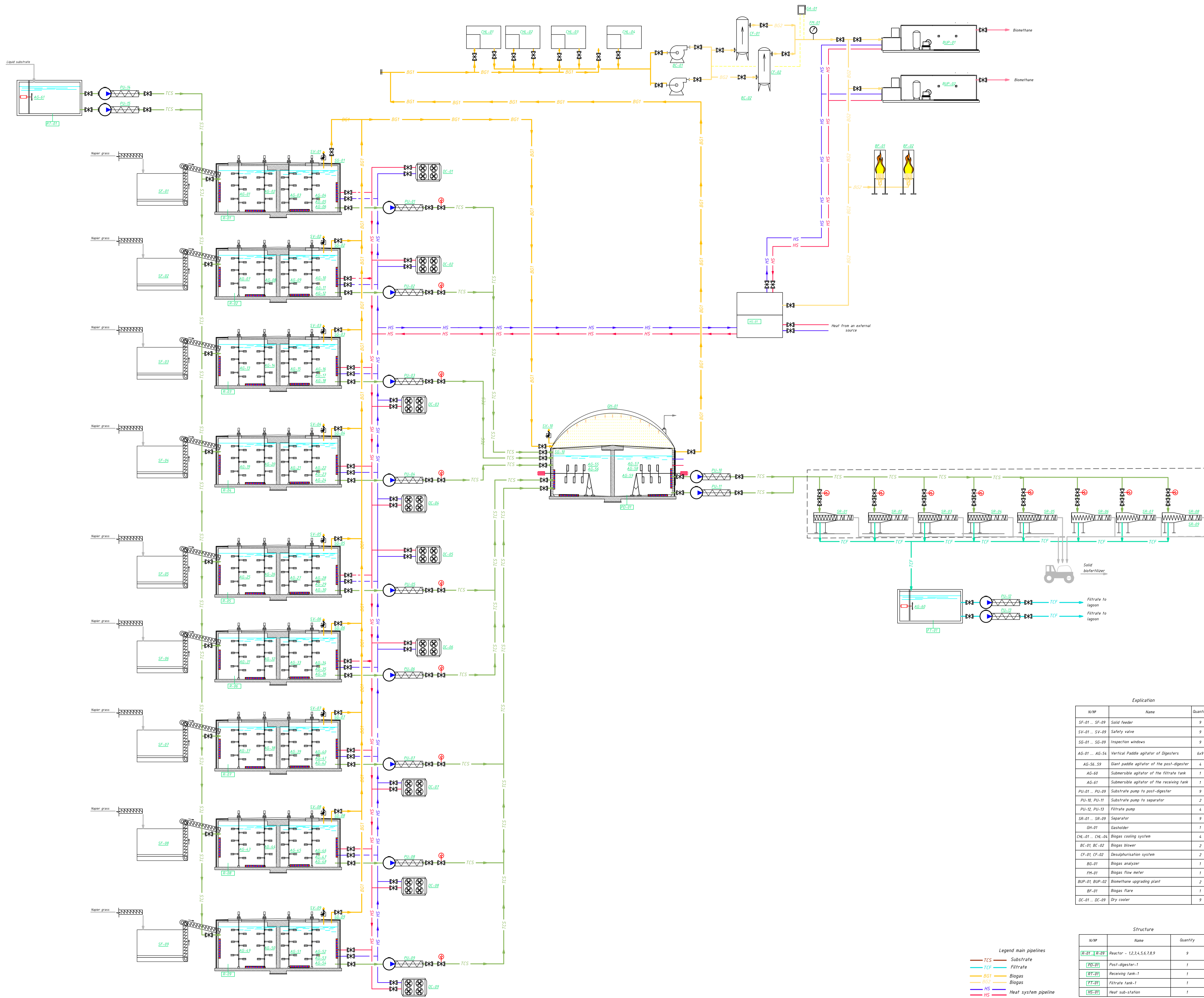

Explication

| N°P | Name | Quantity |
|-------------------|--|----------|
| SF-01 ... SF-09 | Solid feeder | 9 |
| SV-01 ... SV-09 | Safety valve | 9 |
| AG-01 ... AG-09 | Inspection windows | 9 |
| AG-01 ... AG-54 | Vertical Paddle agitator of Digesters | 6x9 |
| AG-56-59 | Giant paddle agitator of the post-digester | 4 |
| AG-60 | Submersible agitator of the filtrate tank | 1 |
| AG-61 | Submersible agitator of the receiving tank | 1 |
| PU-01 ... PU-09 | Substrate pump to post-digester | 9 |
| PU-10, PU-11 | Substrate pump to separator | 2 |
| PU-12, PU-13 | Filtrate pump | 4 |
| SR-01 ... SR-09 | Separator | 9 |
| GH-01 | Gas holder | 1 |
| CHL-01 ... CHL-04 | Biogas cooling system | 4 |
| BC-01, BC-02 | Biogas blower | 2 |
| CF-01, CF-02 | Desulphurisation system | 2 |
| BG-01 | Biogas analyzer | 1 |
| FM-01 | Biogas flow meter | 1 |
| BUP-01, BUP-02 | Biomethane upgrading plant | 2 |
| BF-01 | Biogas flare | 1 |
| DC-01 ... DC-09 | Dry cooler | 9 |

Structure

| N°P | Name | Quantity |
|---------------|-----------------------------|----------|
| R-01 ... R-09 | Reactor - 1,2,3,4,5,6,7,8,9 | 9 |
| PD-01 | Post-digester-1 | 1 |
| RT-01 | Receiving tank-1 | 1 |
| FT-01 | Filtrate tank-1 | 1 |
| TSS-01 | Heat sub-station | 1 |

Legend main pipelines

- TCS Substrate
- TCF Filtrate
- BG1 Biogas
- BG2 Biogas
- HS Heat system pipeline

Biogas plant layout

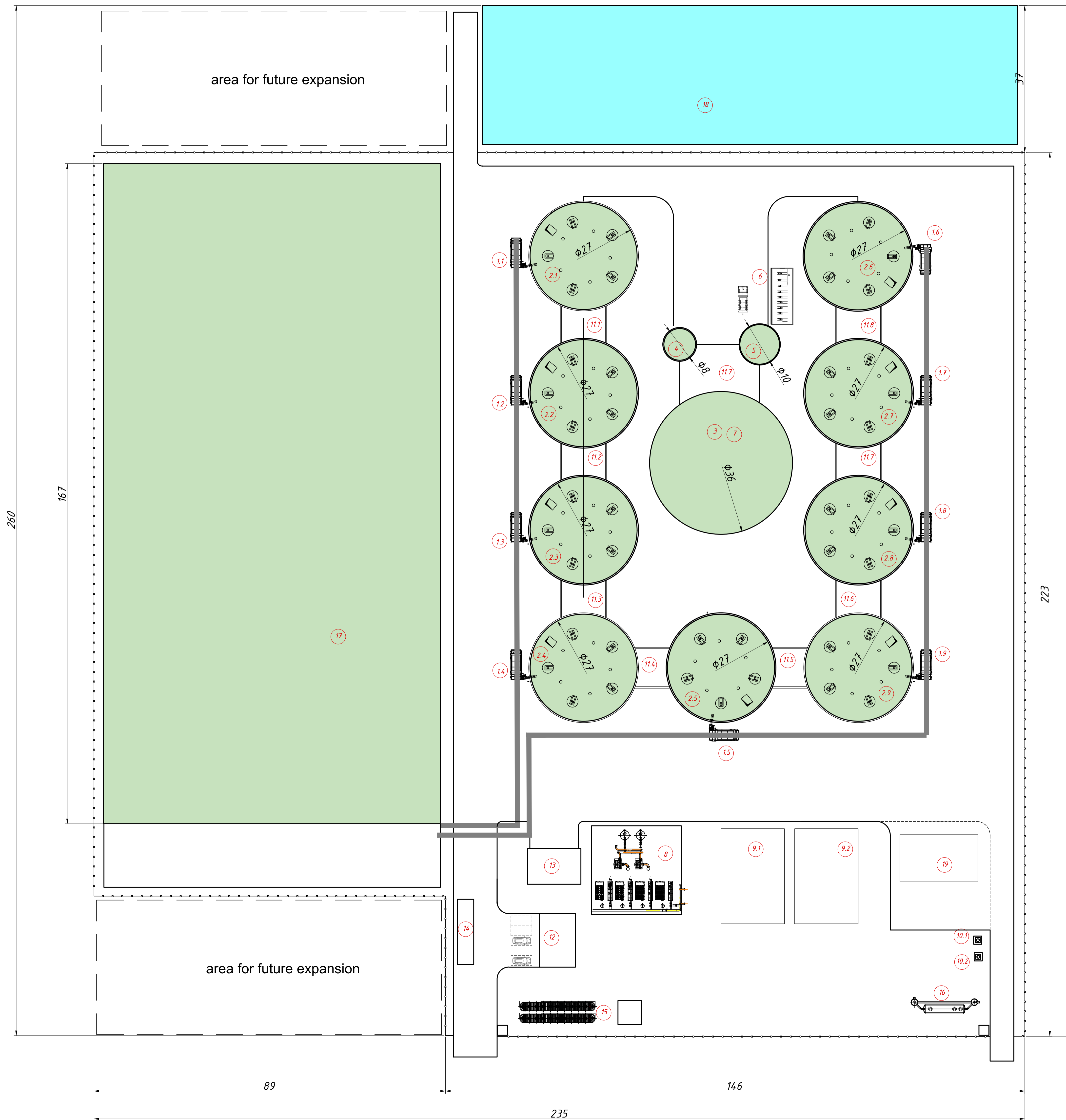

Explication

| N/№ | Name | Note |
|-----|---|------|
| 1 | Solid loader | |
| 2 | Reactor | |
| 3 | Post-digester | |
| 4 | Receiving tank | |
| 5 | Filtrate tank | |
| 6 | Separator platform | |
| 7 | Gasholder | |
| 8 | Gas treatment site | |
| 9 | Biomethane upgrading plant | |
| 10 | Biogas flare | |
| 11 | Equipment room | |
| 12 | Spare parts warehouse | |
| 13 | Technical room | |
| 14 | Truck Scale (Weighbridge) | |
| 15 | Water storage tanks and pumping station | |
| 16 | Rainwater treatment facilities | |
| 17 | Silage storage | |
| 18 | Lagoon | |
| 19 | BioCNG refueling station | |

Total area of the territory- 59.3 ha (133.18 acres)

| Biogas plant | | | | | |
|--|-------------------|-----------|----------------------------|-----------------------|-------------------------|
| Name equipment | Instal. Pow. (kW) | Q-y (pcs) | Total installed power (kW) | Working hours per day | Consumption kWh per day |
| Conveyor (transportation line) | 44,0 | 1 | 44,0 | 8,0 | 352,0 |
| Loader V=15 m ³ | 16,0 | 9 | 144,0 | 6,0 | 864,0 |
| Screw set. | 22,0 | 9 | 198,0 | 6,0 | 1188,0 |
| Digester Vertical agitator | 15,0 | 54 | 810,0 | 18,0 | 14580,0 |
| Post-digester giant paddle agitator | 11,0 | 5 | 55,0 | 12,0 | 660,0 |
| Submersible mixer in receiving tank | 5,5 | 1 | 5,5 | 8,0 | 44,0 |
| Submersible mixer in filtrate tank | 5,5 | 1 | 5,5 | 12,0 | 66,0 |
| Biogas cooling system | 69,0 | 4 | 276,0 | 24,0 | 6624,0 |
| Biogas compressor | 75,0 | 2 | 150,0 | 12,0 | 1800,0 |
| Separator | 5,5 | 9 | 49,5 | 10,0 | 495,0 |
| Substrate pump to post-digester | 11,0 | 9 | 99,0 | 3,0 | 297,0 |
| Substrate pump to separator | 18,5 | 2 | 37,0 | 10,0 | 370,0 |
| Liquid substrate pump | 18,5 | 2 | 37,0 | 5,0 | 185,0 |
| Filtrate pump | 18,5 | 3 | 55,5 | 6,0 | 333,0 |
| Air compressor for gasholder lock | 1,5 | 1 | 1,5 | 1,0 | 1,5 |
| Air blower for double membrane | 1,0 | 1 | 1,0 | 24,0 | 24,0 |
| Digester cooling system | 4,0 | 9 | 36,0 | 24,0 | 864,0 |
| Circulation pump for supplying heat carrier to the digester | 0,8 | 9 | 6,8 | 24,0 | 162,0 |
| Circulation pump for supplying heat carrier to the digester cooling system | 2,0 | 7 | 14,0 | 24,0 | 336,0 |
| Circulating pump feeding hot water at technical building | 0,1 | 1 | 0,1 | 24,0 | 1,9 |
| Propylene glycol pump station | 0,8 | 1 | 0,8 | 0,5 | 0,4 |
| Drinage pump | 1,0 | 4 | 4,0 | 0,5 | 2,0 |
| Lighting of the biogas plant territory | 1,0 | 1 | 1,0 | 8,0 | 8,0 |
| Spot light for digesters inspection windows | 0,1 | 1 | 0,1 | 0,5 | 0,0 |
| Working lighting of switchboard | 0,1 | 1 | 0,1 | 0,5 | 0,1 |
| Oxygen generator | 5,5 | 1 | 5,5 | 12,0 | 66,0 |
| Total installed power, kW | | | 1993 | | |
| Total consumed electric energy, kWh per day | | | | | 29324 |
| Total consumed power, kW | | | | | 1222 |

| Biogas upgrading plant | | | | | |
|---|-------------------|-----------|----------------------------|-----------------------|-------------------------|
| Name equipment | Instal. Pow. (kW) | Q-y (pcs) | Total installed power (kW) | Working hours per day | Consumption kWh per day |
| Biogas upgrading plant | 819,7 | 1 | 819,7 | 24,0 | 19673,3 |
| Total installed power, kW | | | 819,7 | | |
| Total consumed electric energy, kWh per day | | | | | 19673 |
| Average consumed electric power, kW | | | | | 820 |

| | | | | | |
|---|--|--|--|--|------|
| Total average consumed electric power, kW | | | | | 2042 |
|---|--|--|--|--|------|

Biogas plant 1000 tpd Napier grass 33 % TS - 76,4 tonnes bioCNG per day

| Pos | Name | Number of units | Unit price, EUR | Discounts* | Discounted unit price, EUR | Discounted price sub-total, EUR | |
|-----|---|-----------------|---------------------------------|------------|----------------------------|---------------------------------|--------|
| 1 | Detailed design | 1 | 165.000 | 0% | 0 | 165.000 | |
| 2 | Supervision | 1 | 70.000 | 0% | 0 | 70.000 | |
| 3 | Startup and training | 1 | 70.000 | 0% | 0 | 70.000 | |
| 4 | Living and travel expences | 1 | 70.000 | 0% | 0 | 70.000 | |
| 5 | Delivery of the equipment and CHPs | 48 | 10.000 | 0% | 0 | 480.000 | |
| 6 | Laboratory | 1 | 27.000 | 0% | 0 | 27.000 | |
| 7 | Reactor vertical agitator 15kW | 54 | 84.000 | 0% | 0 | 4.536.000 | |
| 8 | Frame for agitators pos.7 | 54 | 7.000 | 0% | 0 | 378.000 | |
| 9 | Post-digester paddle agitator 11kW | 5 | 54.000 | 0% | 0 | 270.000 | |
| 10 | Receiving tank submersible agitator 5,5kW | 1 | 18.000 | 0% | 0 | 18.000 | |
| 11 | Filtrate submersible agitator 5,5kW | 1 | 18.000 | 0% | 0 | 18.000 | |
| 12 | Conveyor transportation line | 1 | 350.000 | 0% | 0 | 350.000 | |
| 13 | Solid feeder 15m3 | 9 | 75.000 | 0% | 0 | 675.000 | |
| 14 | Screw set | 9 | 115.000 | 0% | 0 | 1.035.000 | |
| 15 | Liquid substrate pump 18,5kW | 2 | 32.000 | 0% | 0 | 64.000 | |
| 16 | Substrate pump 11kW | 9 | 29.000 | 0% | 0 | 261.000 | |
| 17 | Digested substrate pump 11kW | 9 | 29.000 | 0% | 0 | 261.000 | |
| 18 | Filtrate supply pump 18,5kW | 2 | 32.000 | 0% | 0 | 64.000 | |
| 19 | Separator | 9 | 58.000 | 0% | 0 | 522.000 | |
| 20 | Gasholder 1/5D 2905 m3 | 1 | 125.000 | 0% | 0 | 125.000 | |
| 21 | Biogas chiller 4600 m3/h | 4 | 265.000 | 0% | 0 | 1.060.000 | |
| 22 | Biogas blower 9200 m3/h | 2 | 57.000 | 0% | 0 | 114.000 | |
| 23 | Desulphurization column with active coal 1000 kg | 2 | 55.000 | 0% | 0 | 114.000 | |
| 24 | Biogas flare 4600 m3/h | 2 | 290.000 | 0% | 0 | 580.000 | |
| 25 | Gas analyzer | 2 | 27.000 | 0% | 0 | 54.000 | |
| 26 | Gas conditioning unit | 1 | 148.000 | 0% | 0 | 148.000 | |
| 27 | Over- and under pressure safeguard | 10 | 12.000 | 0% | 0 | 120.000 | |
| 28 | Sight glasses/viewing windows with projector | 10 | 7.000 | 0% | 0 | 70.000 | |
| 29 | Water supply and canalization system | 1 | 150.000 | 0% | 0 | 150.000 | |
| 30 | Heat supply station | 1 | 168.000 | 0% | 0 | 168.000 | |
| 31 | Dry-cooler (Substrate cooling system for fermenter) | 9 | 36.000 | 0% | 0 | 324.000 | |
| 32 | Automation and electric cabinet | 1 | 840.000 | 0% | 0 | 840.000 | |
| 33 | Electric valves | 30 | 9.000 | 0% | 0 | 270.000 | |
| 34 | Sensors (set) | 12 | 27.000 | 0% | 0 | 324.000 | |
| 35 | Reserve diesel generagor 1MW | 1 | 500.000 | 0% | 0 | 500.000 | |
| 36 | Oxygen generator | 1 | 200.000 | 0% | 0 | 200.000 | |
| 37 | Compressor 4180 m3/h 250 bar | 2 | 650.000 | 0% | 0 | 1.300.000 | |
| 38 | Biogas upgrading plant to biomethane 4180 m3/h | 1 | 7.000.000 | 0% | 0 | 7.000.000 | |
| 39 | Construction and installation | 1 | 7.500.000 | 0% | 0 | 7.500.000 | Client |
| 40 | Weight control (truck scale) | 1 | 50.000 | 0% | 0 | 50.000 | Client |
| 41 | Silage storage for the grass 86 000 m3 | 1 | 1.000.000 | 0% | 0 | 1.000.000 | Client |
| 42 | Filtrate lagoon 20 000 m3 | 1 | 220.000 | 0% | 0 | 220.000 | Client |
| | | | by ZORG, EUR | | | 22.795.000 | |
| | | | by Client, EUR | | | 8.770.000 | |
| | | | TOTAL Zorg + Client, EUR | | | 31.565.000 | |

Biogas plant 1000 tpd Napier grass 27% TS - 62,5 tonnes bioCNG per day

| Pos | Name | Number of units | Unit price, EUR | Discounts* | Unit price, EUR | Price sub-total, EUR |
|-----|---|-----------------|---------------------------------|------------|-----------------|----------------------|
| 1 | Detailed design | 1 | 165.000 | 0% | 0 | 165.000 |
| 2 | Supervision | 1 | 70.000 | 0% | 0 | 70.000 |
| 3 | Startup and training | 1 | 70.000 | 0% | 0 | 70.000 |
| 4 | Living and travel expences | 1 | 70.000 | 0% | 0 | 70.000 |
| 5 | Delivery of the equipment and CHPs | 51 | 8.500 | 0% | 0 | 433.500 |
| 6 | Laboratory | 1 | 27.000 | 0% | 0 | 27.000 |
| 7 | Reactor vertical agitator 15kW | 54 | 84.000 | 0% | 0 | 4.536.000 |
| 8 | Frame for agitators pos.7 | 54 | 7.000 | 0% | 0 | 378.000 |
| 9 | Post-digester paddle agitator 11kW | 5 | 54.000 | 0% | 0 | 270.000 |
| 10 | Submersible agitator of the Receiving tank 5,5kW | 1 | 18.000 | 0% | 0 | 18.000 |
| 11 | Filtrate submersible agitator 5,5kW | 1 | 18.000 | 0% | 0 | 18.000 |
| 12 | Conveyor transportation line | 1 | 350.000 | 0% | 0 | 350.000 |
| 13 | Solid feeder 15m3 | 9 | 75.000 | 0% | 0 | 675.000 |
| 14 | Screw set | 9 | 115.000 | 0% | 0 | 1.035.000 |
| 15 | Liquid substrate pump 18,5kW | 2 | 32.000 | 0% | 0 | 64.000 |
| 16 | Substrate pump 11kW | 9 | 29.000 | 0% | 0 | 261.000 |
| 17 | Digested substrate pump 11kW | 9 | 29.000 | 0% | 0 | 261.000 |
| 18 | Filtrate supply pump 18,5kW | 2 | 32.000 | 0% | 0 | 64.000 |
| 19 | Separator | 9 | 58.000 | 0% | 0 | 522.000 |
| 20 | Gasholder 1/5D 2905m3 | 1 | 125.000 | 0% | 0 | 125.000 |
| 21 | Biogas chiller | 4 | 265.000 | 0% | 0 | 1.060.000 |
| 22 | Biogas blower 7500 m3/h | 2 | 57.000 | 0% | 0 | 114.000 |
| 23 | Desulphurization column with active coal 1000 kg | 2 | 55.000 | 0% | 0 | 114.000 |
| 24 | Biogas flare 3750 m3/h | 2 | 210.000 | 0% | 0 | 420.000 |
| 25 | Gas analyzer | 2 | 27.000 | 0% | 0 | 54.000 |
| 26 | Gas conditioning unit | 1 | 148.000 | 0% | 0 | 148.000 |
| 27 | Over- and under pressure safeguard | 10 | 12.000 | 0% | 0 | 120.000 |
| 28 | Sight glasses/viewing windows with projector | 10 | 6.000 | 0% | 0 | 60.000 |
| 29 | Water supply and canalization system | 1 | 150.000 | 0% | 0 | 150.000 |
| 30 | Heat supply station | 1 | 168.000 | 0% | 0 | 168.000 |
| 31 | Dry-cooler (Substrate cooling system for fermenter) | 10 | 36.000 | 0% | 0 | 360.000 |
| 32 | Automation and electric cabinet | 1 | 840.000 | 0% | 0 | 840.000 |
| 33 | Sensors (set) | 12 | 27.000 | 0% | 0 | 324.000 |
| 34 | Electric valves | 30 | 9.000 | 0% | 0 | 270.000 |
| 35 | Reserve diesel generator 1MW | 1 | 500.000 | 0% | 0 | 500.000 |
| 35 | Oxygen generator | 1 | 200.000 | 0% | 0 | 200.000 |
| 36 | Biomethane compressor 250 bar | 2 | 750.000 | 0% | 0 | 1.500.000 |
| 37 | Biomethane upgrader | 1 | 7.000.000 | 0% | 0 | 7.000.000 |
| 38 | Construction and installation | 1 | 7.500.000 | 0% | 0 | 7.500.000 |
| 39 | Weight control (truck scale) | 1 | 50.000 | 0% | 0 | 50.000 |
| 40 | Silage storage for the grass 86 000 m3 | 1 | 1.000.000 | 0% | 0 | 1.000.000 |
| 41 | Filtrate lagoon 20 000 m3 | 1 | 220.000 | 0% | 0 | 220.000 |
| | | | by ZORG, EUR | | | 22.814.500 |
| | | | by Client, EUR | | | 8.770.000 |
| | | | TOTAL Zorg + Client, EUR | | | 31.584.500 |





Client
Client
Client
Client

Implementation terms and payment

| Year | 2025 | | | | | 2026 | | | | | | | | | | | |
|-----------------------|------|---|-----|-----|-----|------|-----|-----|-----|---|-----|-----|-----|-----|-----|-----|--|
| | 8 | 9 | 10 | 11 | 12 | 1 | 2 | 3 | 4 | 5 | 6 | 7 | 8 | 9 | 10 | 11 | |
| Project documentation | 50% | | 50% | | | | | | | | | | | | | | |
| Approvals and permits | | | | | | | | | | | | | | | | | |
| Equipment supply | | | | 30% | | 30% | | 30% | 10% | | | | | | | | |
| BUP | | | | 30% | | | | | | | | 70% | | | | | |
| Construction | | | | | | | | | | | | | | | | | |
| Supervision | | | | | 20% | | 20% | | 20% | | 20% | | 10% | | | | |
| Biogas plant start-up | | | | | | | | | | | | | 25% | 25% | 25% | 25% | |

Contracts

Project implementation is executed simultaneously under several contracts

-  **Engineering contract**
-  **Equipment supply contract**
-  **Supervision contract**
-  **Start-up and training contract**

List of exclusions :

- 1) Topographic and geological surveys 3000-7000 EUR
- 2) Electric transformer and the external electric line 500 kW for start-up, for construction period and 1200 kW for normal operation.
- 3) Construction and installation materials and works, mentioned in appendix 5 of the proposal. Zorg provides preliminary drawings and bill of quantities for your evaluation and our forecast verification.
- 4) External roads to the biogas plant.
- 5) Temporary water supply during the construction and the hydraulic test of reactors at least 500 m³ water per day. It can be a technical quality water from a river, lake, well. Not salty.
- 6) Bacterial seed for the start-up. It can be biomass from another biogas plant. Possible also cow manure, any kind of manure, sludge from city sewage treatment plant. Customer needs to bring the seed one-time during a 1-2-week period and to fill with it at least 15-20% of the reactor volume 600-800 m³. The rest is filled with the water item 5 above.
- 7) Machinery to transport raw material to and from storage to the solid feeders (a truck, a frontal loader, a tractor).
- 8) Machinery to transport filtrate and the digested mass from the biogas plant to the agricultural fields (a truck, a frontal loader, a tractor)
- 9) Activated carbon 1 tonne per year x 4800 EUR/tonne = 4800 EUR
- 10) Microelements 19x 365= 6935l per year x 25 EUR/l= 173 375 EUR
- 11) Fe(OH)₃, Fe(OH)₂ – 730 tonnes per year x 180 EUR/tonne = 131 400 EUR
- 12) Demineralized water to the heating system 10,0 tonnes,
- 13) Spare parts for 2 years - 600 000 EUR



Business center "Twin Yards"
Walter-Gropius-Straße 23,
DE-80807, München, Germany

Mob. +49 1511 457 29 45 (WhatsApp, Viber, Telegram)

igor.reddikh@zorg-biogas.com
www.zorg-biogas.com